

# SMW

## Soil Mixing Wall - System



## The SMW System



Mixing self-hardening slurry in-situ with native soil (SMW) is a cost-effective technique for the construction of walls for groundwater control (cut-off walls), walls for excavation support (retaining walls) as well as for ground improvement.

For walls with shallow depths (typically 6 to 15 m) the BAUER Soil Mixing Wall method (SMW) has been developed. The soil is loosened and immediately mixed with a self-hardening suspension by three adjacent slightly overlapping augers and mixing paddles.

By loosening, conveying and mixing of the soil, minimum friction between rods and mixed soil is ensured. Therefore it is possible to construct walls effectively rigs with medium power supply.

At the same time a very homogeneous soil-cement mixture can be ensured in order to achieve a good quality of the wall.

### **Main advantages of the method are:**

- Small to medium size rigs can be used.
- The in-situ soil is used as a construction material
- Very little generation of spoil (important factor in contaminated areas)
- No vibrations induced during construction (SMW can be used in immediate vicinity to buildings)

## Construction sequence

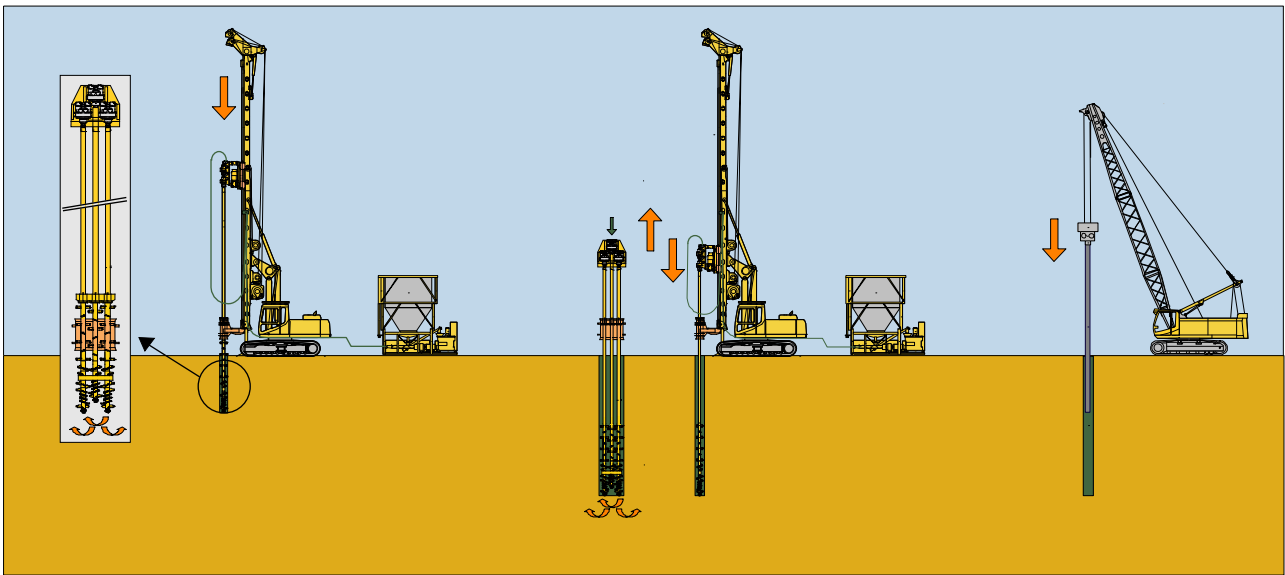

- Step 1:** Excavation of a guide trench for collecting surplus slurry (trench width corresponding to diameter of mixing tool, depth approx. 30 to 50 cm) and align mixing tool with centreline of wall.
- Step 2:** Drill mixing tool into the ground in a continuous operation and concurrently inject self-hardening slurry. The two outer mixing paddles are rotated in opposite direction. The rate of penetration of the mixing tool and the volume of slurry delivered by the pump are controlled in such a way that no surplus slurry appears on the surface.
- Step 3:** After reaching the predetermined design depth, the mixing tool is withdrawn whilst the mixing paddles continue to be rotated. The volume of slurry injected during the withdrawal phase is equal to the displacement volume of the mixing tool.
- Step 4:** During the construction of a continuous wall, individual wall panels are installed in an alternating sequence of primary and secondary panels.
- Step 5:** Reinforcing elements required for structural purposes can be inserted into the completed soil mixing wall.
- Insertion of sheet pile wall elements or steel stanchions into the not fully hardened wall. The spacing between individual stanchions is dependent on the characteristic strength of the hardened wall (arching effect) and the intensity of static loading.
  - Alternative: Installation of cast-in-situ bored piles in the hardened wall. The spacing between individual piles is dependent on the characteristic strength of the hardened wall (arching effect).

### Sequence of wall construction

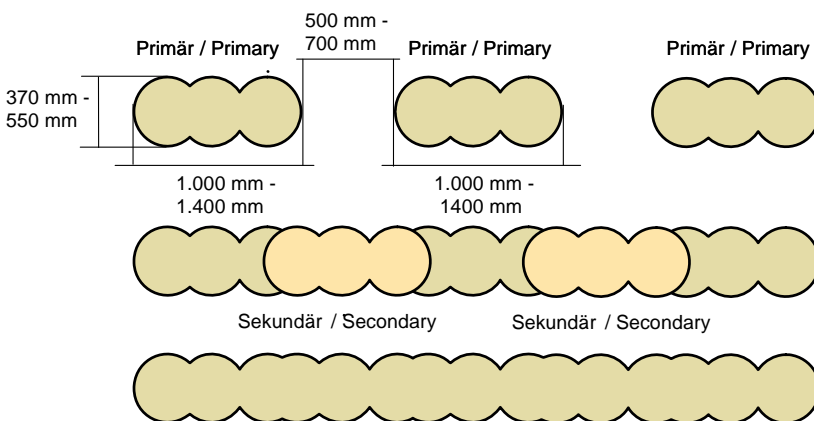

A continuous wall is formed in a series of overlapping primary and secondary panels. Overcutting into fresh adjacent panels is called „fresh-in-fresh method“.

## Productivity factors

	favourable conditions	Unfavourable conditions
<b>Soil structure</b>	uniform soil structure	layered soil structure
<b>Soil type</b>	loose to medium dense gravelly sand, silty sand	dense to very dense soil, cobbles and boulders embedded in soil, stiff or hard soil, cohesive or organic soil (reduction of the final strength)
<b>Site geometry</b>	long, straight wall sections	irregular wall layout
<b>Wall depth</b>	wall depth > 10 m	wall depth < 10 m (influence of non-productive periods such as moving, setting-up)

### Limitations of the process

The SMW process is a technique with wide-ranging applications. In order to avoid economical and technical problems during the construction of the wall and also quality-related problems on the completed wall, the following process-specific limitations should be taken into account:

- Capacity to drill in rocky types of soil or in soils containing cobbles and boulders
- Reduction in the strength of the completed wall in cohesive or organic soils.



## Rate of production

<b>Recommended rates of production</b>	favourable conditions:	20 - 24 m <sup>2</sup> per hour
	unfavourable conditions	12-15 m <sup>2</sup> per hour

(Net production per m<sup>2</sup> of completed wall including overlaps and in-situ mixing)

When determining the theoretical total production it is recommended to apply a utilization rate ranging from 65 - 80%

<b>Personnel</b>	1 operator SMW-rig
	1 mixing plant operator
	1 foreman
	(1 helper)

---

## Slurry

---

### Components

The slurry mix used in the construction of SMW panels consists normally of:

- Cement OPC or blast furnace cement CEM III/B 32,5
- Bentonite
- Additives plasticizer, retarder or polymer additions
- Admixtures fly ash

### Mix proportions and consumption values

The mix design is governed by various factors:

#### Application:

- Cut-off wall (permeability, strength, plasticity, erosion stability)
- Retaining wall (strength, permeability, plasticity of fresh mix - as precondition for the installation of reinforcement)

#### Soil properties:

Particle size distribution, grain size, fines content, organic content, relative density, SPT values, porosity, groundwater level, groundwater chemistry

The mix design should always - especially in unknown conditions - be determined by suitability tests prior to the start of construction.

The following tables give values for an initial design of the mix proportions. They should be used for reference only. They have to be confirmed by suitability tests.

#### Binder slurry (typical predesign values)

	Cut-off wall	Retaining wall
Cement	250 - 450 kg/m <sup>3</sup> slurry	750 – 1.200 kg/m <sup>3</sup> slurry
Bentonite	30 – 50 kg/m <sup>3</sup> slurry	15 – 30 kg/m <sup>3</sup> slurry
w/c ratio	2,0 - 4,0	0,5 - 1,0

#### Wall characteristics (typical predesign values)

	Cut-off wall	Retaining wall
Compressive strength $q_u$	0,5 - 2 MPa	5 - 15 MPa
Permeability $k_f$	ca. $1 \times 10^{-8}$ m/sec	
Cement content in soil	100 - 200 kg/m <sup>3</sup> soil	200 - 450 kg/m <sup>3</sup> soil

## SMW-Mixing units

The SMW mixing units are available in two dimensions: (**SMW 370** and **SMW 550**)  
 Wall thickness of 370 mm or 550 mm can be reached.

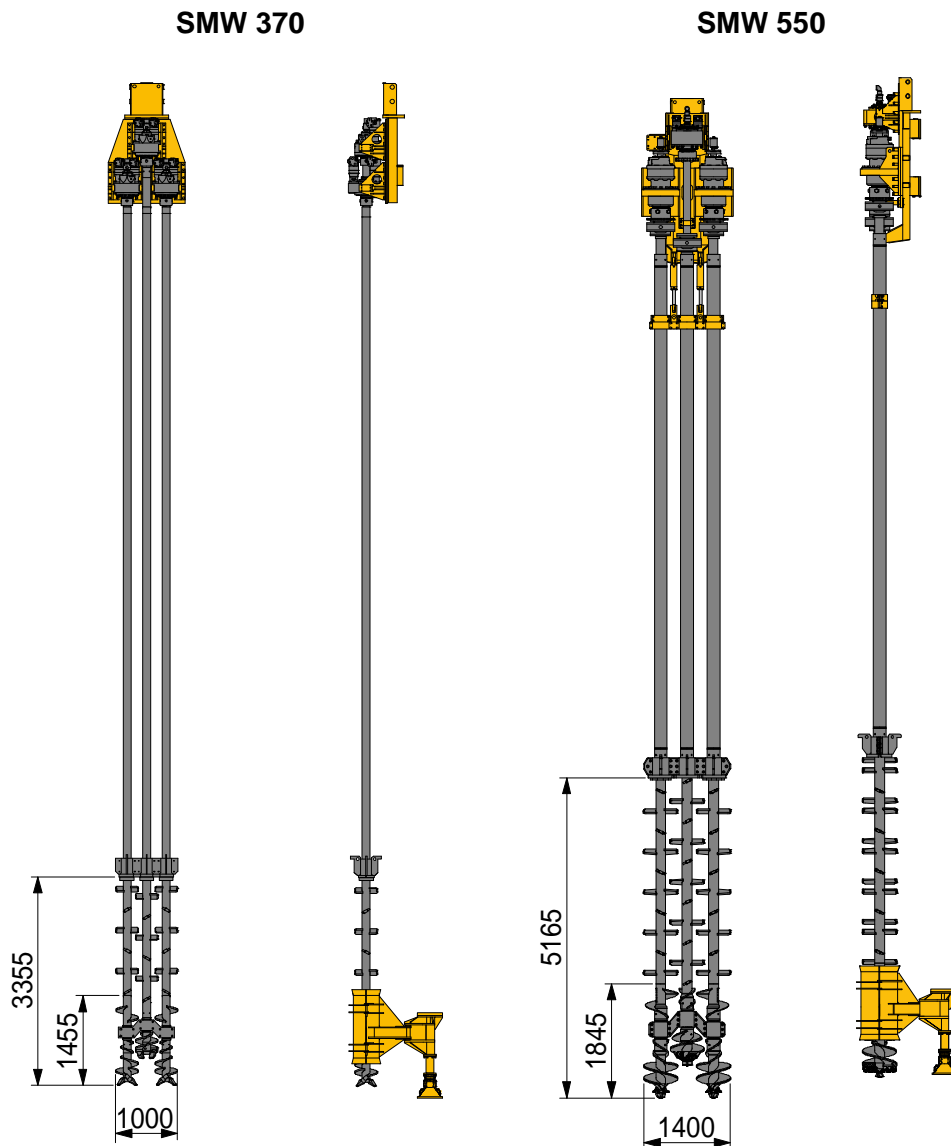

**Technical data:** Rotary drives

**Type** SMW 370  
**Manufacturer** EURODRILL

**2 Rotary drives (outer)**  
 Speed (max.) 50 rpm  
 Torque (max.) 23.6 kNm

**1 Rotary drive (central)**  
 Speed (max.) 68 rpm  
 Torque (max.) 14 kNm

**Technical data:** Rotary drives

**Type** SMW 550  
**Manufacturer** EURODRILL

**2 Rotary drives (outer)**  
 Speed (max.) 25 rpm  
 Torque (max.) 51 kNm

**1 Rotary drive (central)**  
 Speed (max.) 64 rpm  
 Torque (max.) 19 kNm

In the SMW method the soil is loosened and mixed with self hardening slurry with three slightly overlapping augers and mixing paddles.

A SMW-mixing unit consists of four sections:

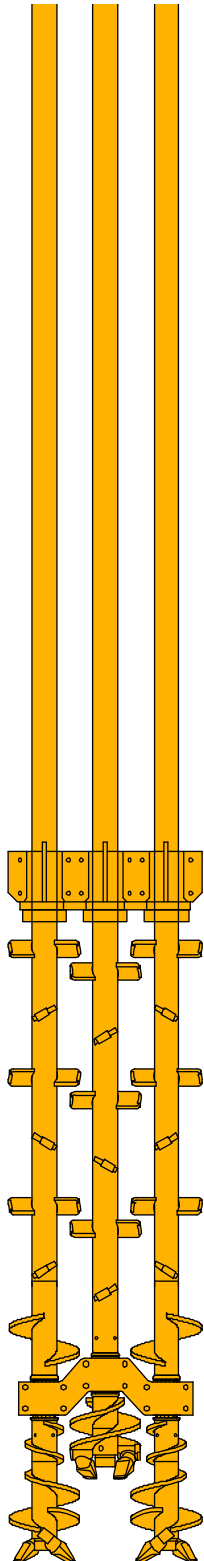

Section 4:

The rods end with a simple tube extension. This ensures the required depth of the panel, without the building up of friction. The mixed soil acts like a sliding guide for the three parallel rods.

Section 3:

**4** The mixing area is located right above the augers (Section 2). Counter-rotating and overlapping of the paddles ensures a homogeneous mixing over the whole panel area.

Section 2:

Short augers are moving the soil and the slurry upwards. The auger flights of the outer strings are smaller in the starter area of the inner auger to prevent collision of the three augers.

Section 1:

The soil is loosened at the bottom of each auger with two cutting edges and a central pilot bit. The outer augers are rotating in opposite direction. The starter of the central auger is placed at a slightly higher position. While cutting the soil, slurry is pumped into the soil through radial nozzles at the bottom of the augers.



## Base carrier (BG-series)



	BG 18 / BG 20	BG 24 / BG 28
<b>SMW - unit (recommended)</b>	<b>SMW 370</b>	<b>SMW 370 / SMW 550</b>
<b>Panel depth (approx.)</b>	<b>13 m - 14,5 m</b>	<b>15,5 m - 18 m</b>
<b>Installed power</b>	<b>186 kW - 205 kW</b>	<b>261 kW - 313 kW</b>
<b>Crowd pull</b>	<b>200 kN - 260 kN</b>	<b>330 kN</b>
<b>Overall height</b>	<b>19,1 m - 20,9 m</b>	<b>21,8 m - 25,4 m</b>
<b>Operating weight (approx.)</b>	<b>53 t - 60 t</b>	<b>60 t - 90 t</b>

## Base carrier (RG-series)

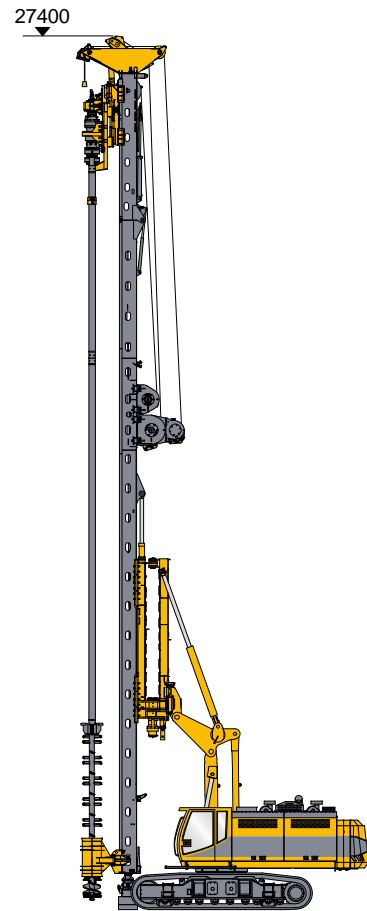
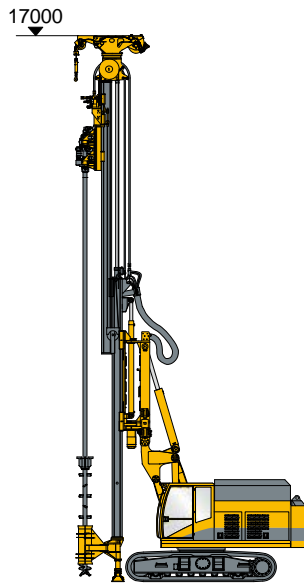

	RG 14 T	RG 16 T	RG 19 T
SMW - unit (recommended)	SMW 370	SMW 370 / SMW 550	SMW 370 / SMW 550
Panel depth (approx.)	10,6 m	11,5 m	14,6 m
Installed power	313 kW	470 kW (570 kW)	470 kW (570 kW)
Crowd pull	120 kN	160 kN	200 kN
Overall height	17,2 m	19,5 m	22,4 m
Operating weight (approx.)	48,5 t	60 t	70 t

	RG 21 T	RG 18 S / RG 20 S	RG 25 S
SMW - unit (recommended)	SMW 370 / SMW 550	SMW 370 / SMW 550	SMW 370 / SMW 550
Panel depth (approx.)	17,1 m	13,9 - 17,3 m	20,0 m
Installed power	470 kW (570 kW)	470 kW (570 kW)	570 kW
Crowd pull	260 kN	400 kN	530 kN
Overall height	25,3 m	20,0 - 24,0 m	27,4 m
Operating weight (approx.)	82,7 t	79 - 80 t	98 t

## Additional equipment

		kW (ca.)	
Slurry mixing station	Minimum capacity 20 m <sup>3</sup> /h (e.g. batch mixer MAT SCC 20 or bigger)	30	
Delivery pump	frequency controlled slurry pump with remote control, capacity depends on volume of panel and speed of mixing.(typically: 200 - 400 l/min, 12 – 15 bar)	18,5	
Agitator tank	approx.3 - 5 m <sup>3</sup> (as buffer for cement slurry)	2,2	
Silos	for cement and bentonite with screw conveyors	2 x 5	
Hydraulic backhoe	for excavation of guide trench, maintenance of working platform, handling of backflow	50	
Hoses	for conveying cement or bentonite slurry from the agitator to the rig. Typically 1,5" or 2" rubber hose (length to suit site requirements)		
Service crane and vibrator	for inserting universal beams into the panel of retaining wall. Size of crane depends on length and weight of beams and vibrator use	60	optional

### Schematic site installation

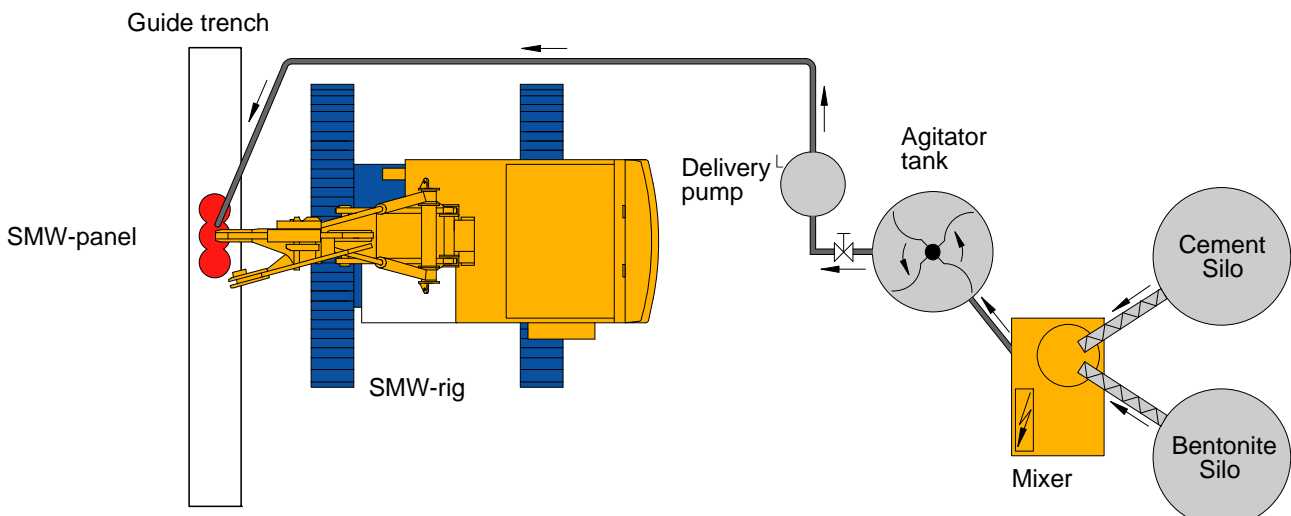

# Quality control

## Prior to construction:

Suitability test to determine mix design.  
Material testing in accordance with QA plan.

## During construction:

Geometric checks of individual panel positions

Slurry tests in accordance with QA plan

Control of production parameters displayed on the monitor of the rig operator:

- Depth
- Volume
- Slurry pressure
- Pumped volume v. time
- Pumped volume v. depth
- Inclination
- Speed of mixing tool

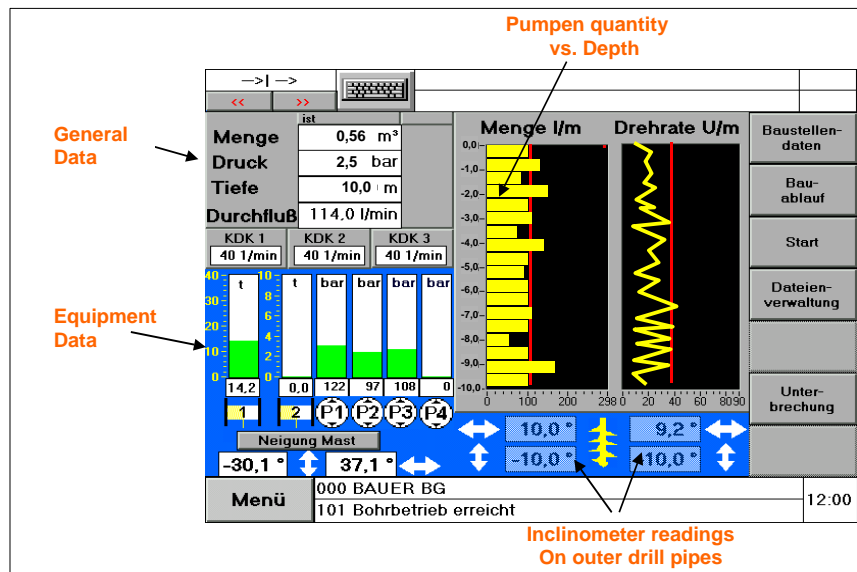

## Documentation:

All production parameters are monitored recorded and stored inside the rig throughout the construction process and can be printed out in the form of a quality assurance record for each individual panel.

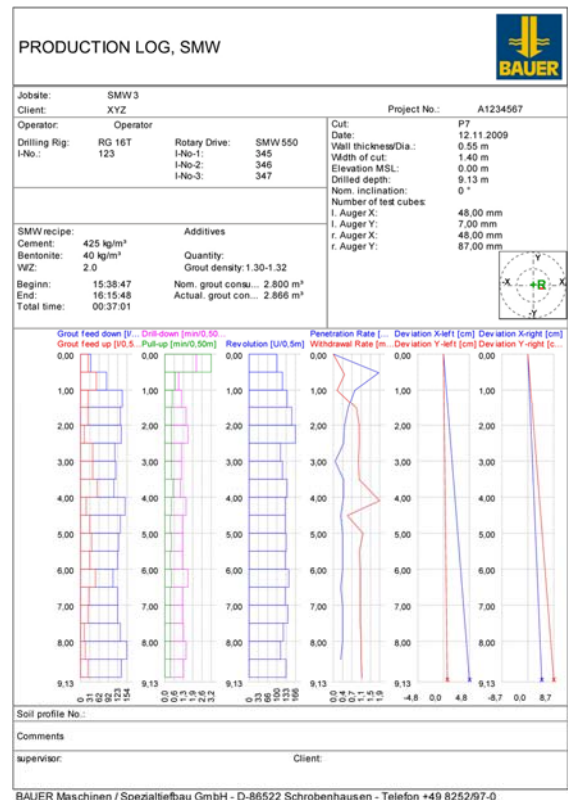
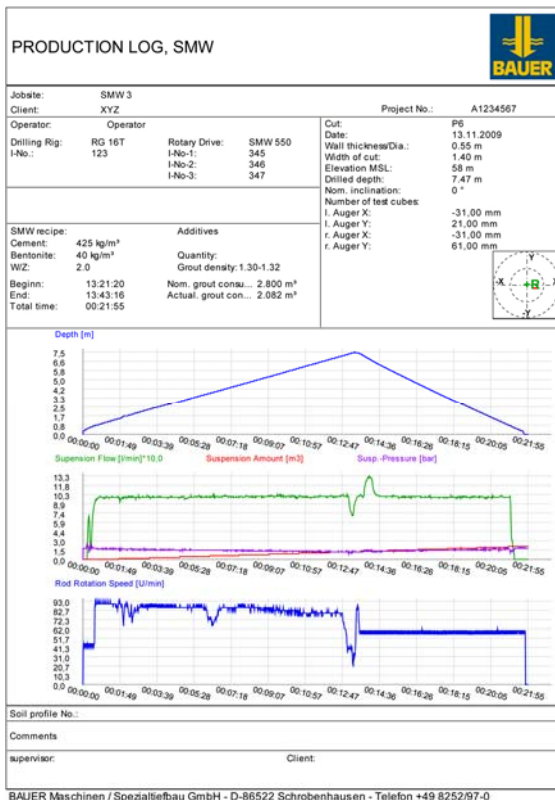

## Site examples



Retaining wall with RG, Sydney, Australia



Cut-off wall with BG, Oberhausen, Germany



Excavated SMW retaining wall, Sydney, Australia



Exposed test shaft, Sydney, Australia



BAUER Maschinen GmbH  
BAUER-Straße 1  
86529 Schrobenhausen, Germany  
Tel.: +49 8252 97-0  
Fax: +49 8252 97-1135  
e-mail: BMA@bauer.de

Design developments and process improvements may require the specification and materials to be updated and changed without prior notice or liability. Illustrations may include optional equipment and not show all possible configurations. These and the technical data are provided as indicative information only, with any errors and misprints reserved.